



OWNER'S MANUAL DUAL INPUT 70A MAXIMUM BATTERY ISOLATORS

Models	Current Rating	No. of outputs
2502	70A	2
2503	70A	3

IMPORTANT SAFETY INSTRUCTION

This manual contains important safety and wiring instructions for the isolator. Read the entire manual before using. Also read all instructions and cautions for the isolator, batteries and equipment in the vicinity of the batteries.

RISK OF EXPLOSIVE GASES! WORKING IN THE VICINITY OF LEAD ACID BATTERIES IS DANGEROUS. BATTERIES GENERATE EXPLOSIVE GASES DURING NORMAL OPERATION. THEREFORE IT IS OF THE UTMOST IMPORTANCE THAT WHEN INSTALLING THE ISOLATOR THESE INSTRUCTIONS ARE FOLLOWED.

Personal Safety Precautions

Adhere to the following personal safety precautions when installing or working with the isolators:

- Someone should be within voice range or close enough to come to your aid when you work near a lead-acid battery.
- Have plenty of fresh water and soap nearby in case battery acid contacts skin, clothing, or eyes.
- Wear complete eye protection and clothing protection. Avoid touching eyes while working near a battery.
- If battery acid contacts skin or clothing, wash them immediately with soap and water. If acid enters the eye, flood the eye with cold, running water for at least ten minutes and get medical attention.
- Never smoke or allow an open flame in the vicinity of the battery.
- Do not drop a metal tool onto the battery. It may short-circuit the battery, spark and may cause an explosion.
- Remove all personal metal items such as rings, bracelets, necklaces, and watches when working near a lead-acid battery. A battery can produce short circuit currents high enough to weld a ring or the like to metal, causing a severe burn.

Preparing to Charge Precautions

Before charging a battery, read the following precautions:

- If the battery or batteries must be removed from the product, always remove the grounded terminal from the battery first.
- Be sure the area around the battery is well ventilated while the battery is being charged. Gas can be forcefully blown away using a piece of cardboard or other non-metallic material as a "hand fan".
- Clean battery terminals. Be careful to keep corrosion from coming into contact with eyes.
- Add distilled water in each cell until battery acid reaches levels specified by the battery manufacturer, if applicable. Do not overfill. Check water levels frequently. For a battery without cell caps, carefully follow the manufacturer's recharging instructions.
- Never allow the charger battery connection ring terminals to touch each other.
- NEVER charge a frozen battery.

INTRODUCTION

The Guest Battery Isolators are specifically designed to efficiently utilize the energy produced by the alternator and distribute the power evenly to each battery.

The isolators are connected between the alternator(s) and the batteries. The difficulty in connecting the isolators is due to the large variety of alternator configurations. This manual illustrates the most common wiring configurations.

When installing a Guest Battery Isolator make sure the proper circuit breaker and wire sizes are utilized.

The Guest Battery Isolators are designed for alternator systems with negative ground and batteries of the same voltage level.

INSTALLATION

Choosing the Battery Isolator location

The battery isolator should have at least eight inches of unobstructed area on all sides of the unit for effective cooling. The case of the battery isolator will become hot during operation. Because the battery isolator is convection cooled (airflow over the fins of the heat sink), the battery isolator MUST be mounted with the fins in the vertical position. Mounting on its back on a horizontal surface may cause the battery isolator to produce excessive heat. Do not install the battery isolator on carpeted, upholstered, or varnished surfaces.

Mounting the Battery Isolator

- Use corrosion resistant #10 sized screws or bolts, backed by a flat washer, and secured to the mounting surface with a split-ring lock washer.
- Hold the isolator to the mounting surface and mark the holes.
- Remove the isolator and drill the mounting holes.
- Align the isolator and assemble the mounting hardware secure.

Wire Size

Current Rating	Recommended Wire Size			
	0 – 15ft	15 – 20ft	20 – 25ft	25 – 30ft
50 Amps	10AWG	10AWG	8AWG	8AWG
70 Amps	8AWG	8AWG	6AWG	6AWG
100 Amps	8AWG	6AWG	6AWG	4AWG
120Amps	4AWG	4AWG	2AWG	2AWG
140Amps	2AWG	2AWG	1AWG	1AWG

Note: The input wiring must match the respective alternator input current rating. The output wiring must match the sum of both alternator input ratings.

Typical Wiring Configuration

Diagram 1 – Standard Alternator to Battery Isolator Configuration

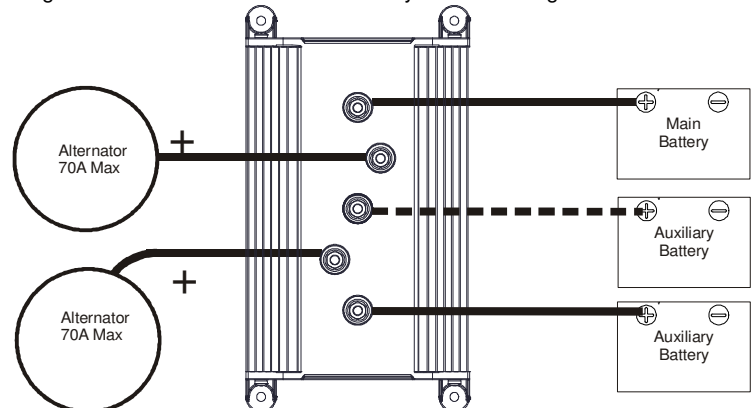

Typical Wiring Configuration (continued)

Diagram2 – Alternator to Battery Isolator with R-Kit

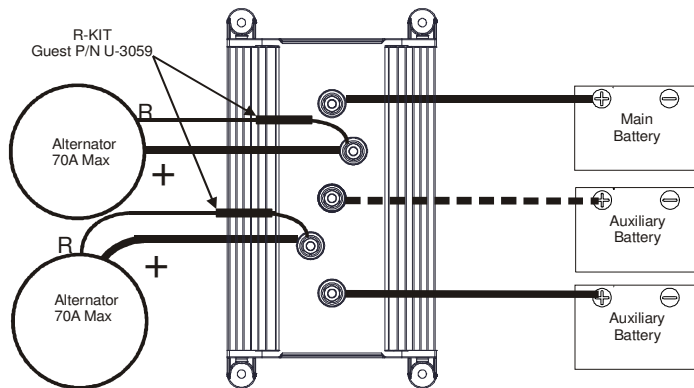

Diagram 3 – Alternator to Battery Isolator with additional battery

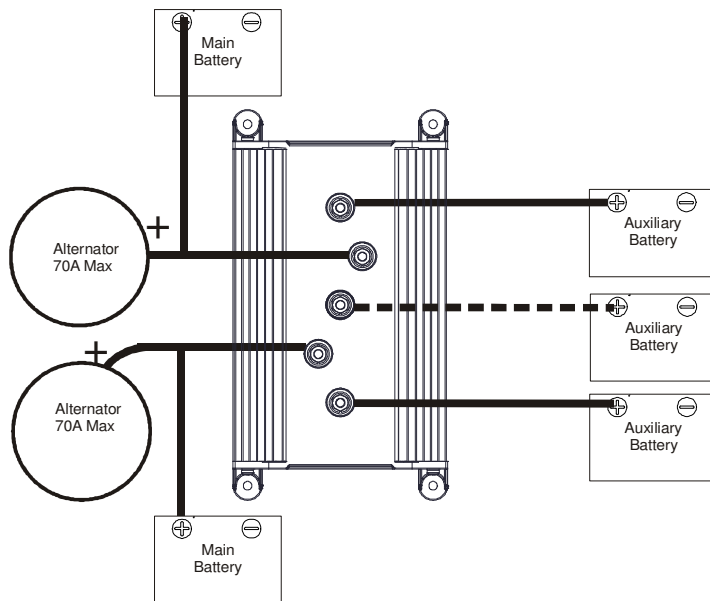
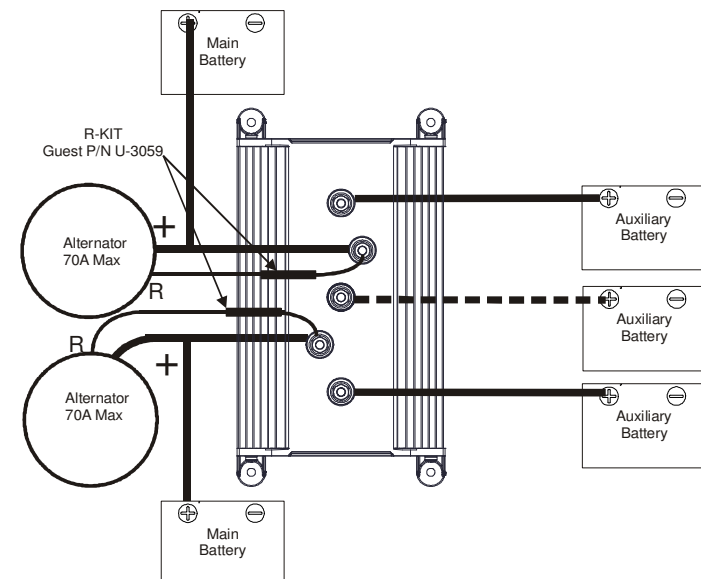

Diagram 4 – Alternator to Battery Isolator with R-Kit and additional battery



Battery Isolator Testing

1. Remove all wire connections from the isolator.
2. Setup a digital multi-meter (DMM) in the diode test mode.
3. Connect the red probe from the DMM to the alternator input (A) and the black probe from the DMM to the battery output terminal to be tested. A good isolator connection will show a reading of 0.4 to 0.6VDC.
4. Connect the DMM black probe to the alternator input (A) and the red probe to the battery output terminal to be tested. A good isolator connection will show a reading of OL.
5. Repeat steps 3 and 4 for the other battery output terminals with respect to each alternator input.

Maintaining the Battery Isolator

Periodically clean both battery and isolator terminals with baking soda and tighten all connections. No other maintenance on the isolator is required.

LIMITED WARRANTY

For two (2) years from the date of original purchase, The Guest Co. will, at its discretion, repair or replace for the original consumer, free of charge, any parts found defective in material or workmanship.

Proof of purchase is required: A computerized register receipt is required. Hand-written receipts are not accepted for warranty proof of purchase. In the absence of a receipt, warranty period will be calculated from date of manufacture printed or stamped on the product.

There is no other expressed warranty. Implied warranties, including those of merchantability and fitness for a particular purpose, are limited to two years from the date of purchase. This is the exclusive remedy and consequential damages are excluded where permitted by law.

Phone: 707-226-9600

Fax: 707-226-9670

e-mail: info@marinco.com

website: www.marinco.com